

**H****Monday 20 May 2013 – Afternoon****GCSE GATEWAY SCIENCE
BIOLOGY B****B731/02** Biology modules B1, B2, B3 (Higher Tier)

Candidates answer on the Question Paper.
A calculator may be used for this paper.

OCR supplied materials:
None

Other materials required:

- Pencil
- Ruler (cm/mm)

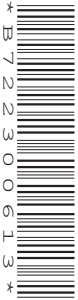
Duration: 1 hour 15 minutes

Candidate forename		Candidate surname	
-----------------------	--	----------------------	--

Centre number						Candidate number				
---------------	--	--	--	--	--	------------------	--	--	--	--

INSTRUCTIONS TO CANDIDATES

- Write your name, centre number and candidate number in the boxes above. Please write clearly and in capital letters.
- Use black ink. HB pencil may be used for graphs and diagrams only.
- Answer **all** the questions.
- Read each question carefully. Make sure you know what you have to do before starting your answer.
- Write your answer to each question in the space provided. Additional paper may be used if necessary but you must clearly show your candidate number, centre number and question number(s).
- Do **not** write in the bar codes.

INFORMATION FOR CANDIDATES

- Your quality of written communication is assessed in questions marked with a pencil (✎).
- The number of marks is given in brackets [] at the end of each question or part question.
- The total number of marks for this paper is **75**.
- This document consists of **24** pages. Any blank pages are indicated.

Answer **all** the questions.

SECTION A- Module 81

1 *Conus magus* is a large tropical sea snail.



(a) The sea snail feeds on fish.

When it detects a fish it fires a hook into it.

The hook contains a powerful poison which paralyses the fish.

The poison stops the release of neurotransmitters.

Explain how this paralyses the fish.

..... [2]

(b) Scientists are investigating the poison produced by the snail.

They think that it could be used as a painkiller in humans.

Describe how a double-blind trial would be designed to see if the poison works.

..... [2]

[Total: 4]

- 2 Linda has a mass of 60 kg.
 She wants to find out if she is eating the correct amount of protein.
 She starts to work out the protein content of all the food she eats in one day.

Food	Mass eaten in g	Protein content per 100g of food	Protein content in Linda's food in g
bread	100	7.8	7.8
butter	50	0.6	0.3
egg	50	12.0	6.0
baked potato	200	2.0
cheese	50	26.0	13.0
chocolate	50	8.0	4.0
chicken	50	21.0	10.5
vegetables	50	0.8
cake	100	5.0	5.0
			total

- (a) Is Linda eating the correct amount of protein?

Complete the table and calculate Linda's estimated average daily requirement of protein (EAR) to help explain your answer.

$$\text{EAR in g} = 0.6 \times \text{body mass in kg}$$

.....
 [3]

- (b) Linda and Sue are both 30 years old and are the same mass.

Suggest and explain a possible reason why Sue might need more protein than Linda.

.....
 [2]

- (c) Three of Linda's friends do **not** eat meat.

Suggest how these friends can still achieve a balanced diet.

.....
 [2]

[Total: 7]

Turn over

3 Sweat glands in the skin release sweat.

(a) Explain how sweat can cool the body down.

.....
 [2]

(b) Some people sweat too much.

This is called hyperhidrosis.

Scientists have discovered that this is caused by a **dominant** allele.

Look at this family tree.

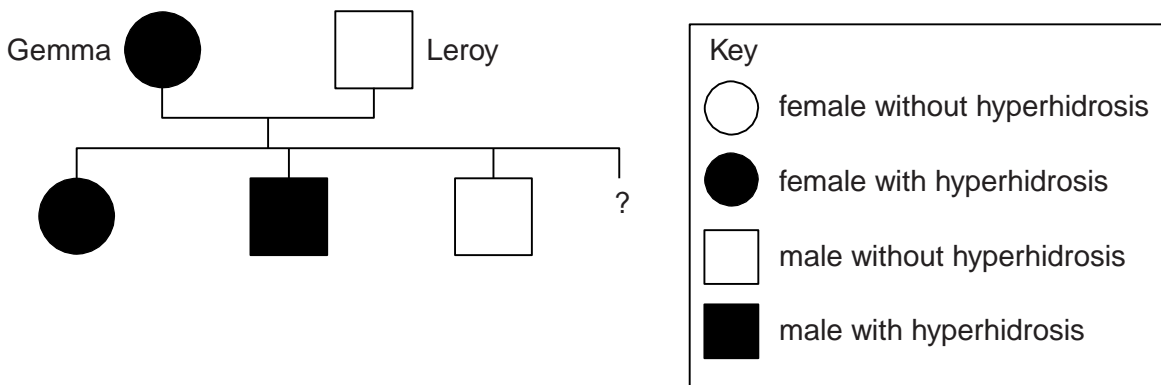

Gemma and Leroy are expecting a fourth child.

What is the probability that it will have hyperhidrosis?

Explain how you worked out your answer.

probability =

explanation

..... [2]

(c) Gemma's doctor injects her with a drug that makes her sweat less.

(i) Put a tick (✓) in the box that describes what this drug changes.

- Gemma's genotype but not her phenotype
- Gemma's phenotype and her genotype
- neither Gemma's phenotype nor her genotype
- Gemma's phenotype but not her genotype

[1]

(ii) The drug contains an antigen made by bacteria.

The drug stops the sweat glands working for about 4 months.

It only works for this long because the antigens are gradually destroyed by Gemma's body.

Explain how Gemma's body destroys antigens.

.....

.....

.....

..... [2]

[Total: 7]

4 Singapore is a small country.

Everyone living in Singapore was offered a health check to test for three conditions.

They were tested:

- for high blood pressure
- for high levels of blood cholesterol
- to see if they failed to respond to insulin.

The check found that one million people had at least one of these conditions.

The pie chart shows the results for these one million people.

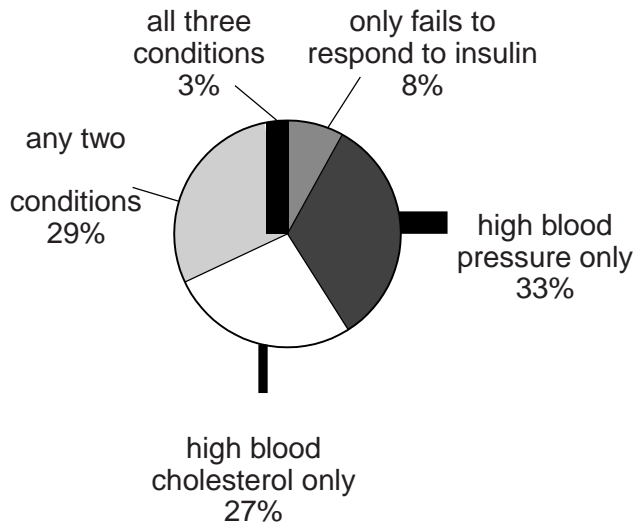

(a) The government is worried about the possible consequences of these results for many of the people.

Explain the most serious consequences of these results for the health of the people.

Use calculations to support your answer.



The quality of written communication will be assessed in your answer to this question.

.....

.....

.....

.....

.....

.....

.....

.....

.....

.....

(b) It is **not** possible from the pie chart to work out how many of the one million people have high blood pressure.

Explain why.

.....
..... [1]

[Total: 7]

Question 5 begins on page 8

SECTION B – Module B2

5 Look at the woodland food web.

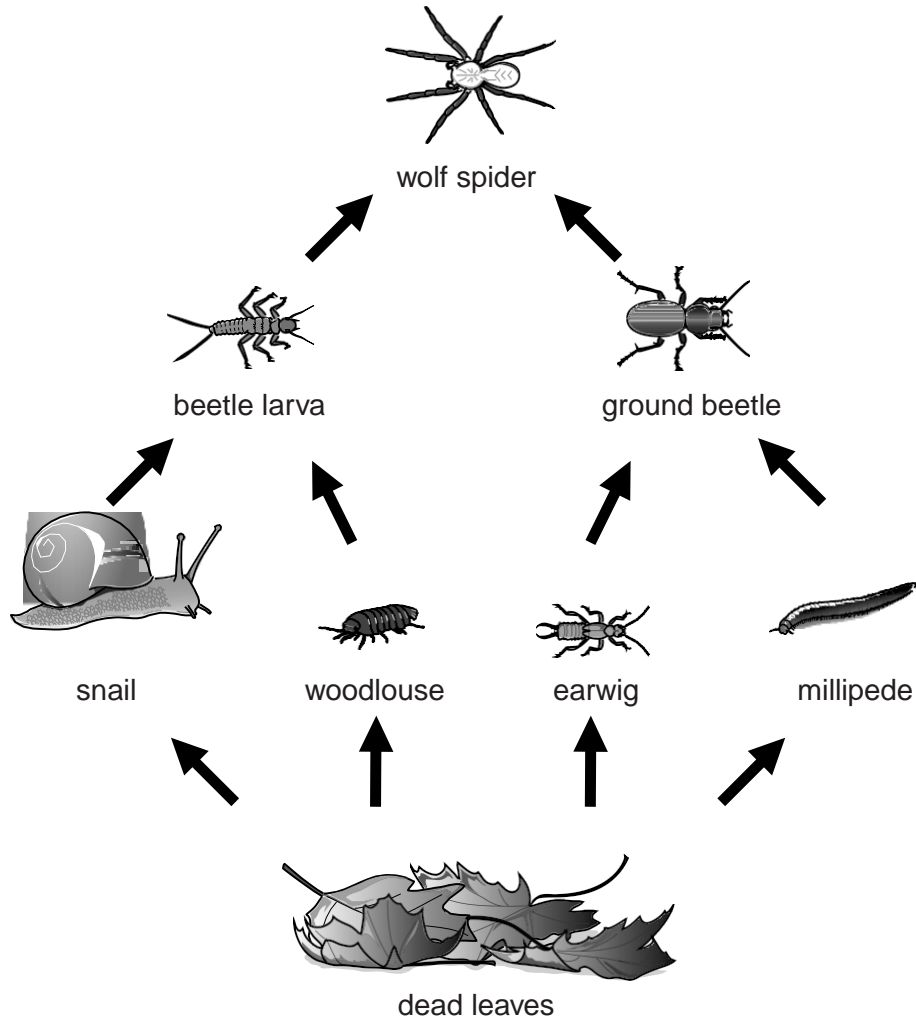

(a) (i) Look at one food chain in this web showing the numbers at each level.

100 dead leaves → **4 snails** → **10 beetle larvae** → **1 wolf spider**

Would you expect the pyramid of numbers and pyramid of biomass to be the same shape for this food chain?

Explain your answer.

.....
 [1]

(ii) The woodlouse and earwig are in the same trophic level.

Some energy from this trophic level does not pass into the next trophic level.

Write down reasons why.

.....

(b) The efficiency of energy transfer between trophic levels can be calculated.

Look at the data on energy flow through four trophic levels.

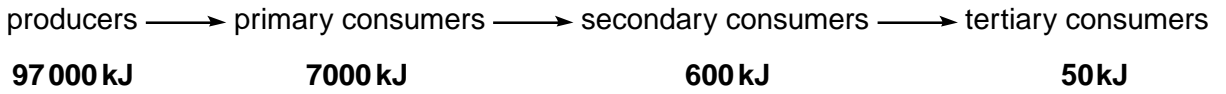

The efficiency of energy transfer between producers and primary consumers is 7.2%.

The efficiency of energy transfer between primary and secondary consumers is 8.6%.

(i) Calculate the efficiency of energy transfer between the secondary and tertiary consumers.

Secondary to tertiary consumers efficiency of energy transfer = % **[1]**

(ii) Use your answer to part (i) to explain why it is unlikely that there would be a fifth trophic level.

.....
.....
..... **[2]**

[Total: 6]

BLANK PAGE

PLEASE DO NOT WRITE ON THIS PAGE

6 This question is about pollution.

(a) The name of one type of mayfly larva that lives in streams is *Ephemera danica*.

(i) What does this name indicate about the classification of this animal?

Write **1** in the box next to the classification indicated by the name *Ephemera*.

Write **2** in the box next to the classification indicated by the name *danica*.

class	<input type="checkbox"/>
family	<input type="checkbox"/>
genus	<input type="checkbox"/>
kingdom	<input type="checkbox"/>
order	<input type="checkbox"/>
species	<input type="checkbox"/>

[1]

(ii) The **binomial system** is used to name *Ephemera danica*.

Why is the binomial system important when scientists name organisms?

.....

..... [1]

(b) Look at the picture of a stonefly larva.

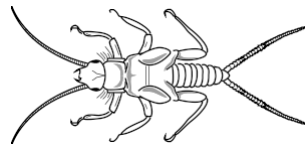

This is an indicator species used to show levels of water pollution.

Stonefly larvae live underneath stones in fast-flowing streams.

Stonefly larvae have adapted legs that end in small hooks and the body is flattened.

Explain why stonefly larvae are described as **specialists**.

.....

.....

.....

..... [2]

(c) Look at the diagrams.

They are indicator species used to show levels of water pollution.

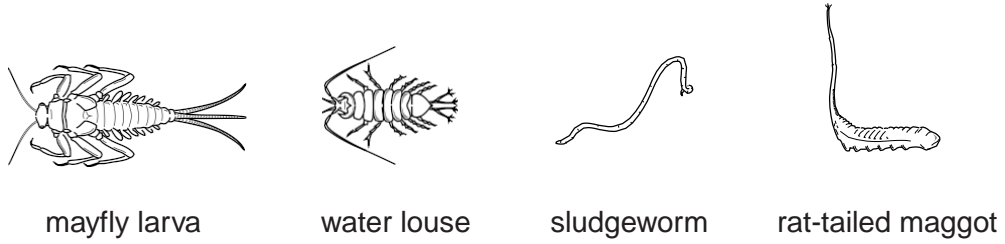

low pollution —————> high pollution

The County Council want to find out pollution levels in a local stream.

Water samples were taken downstream from three different places:

- a country park
- a housing estate
- a factory.

The indicator species were measured in each sample.

Results were plotted on a graph.

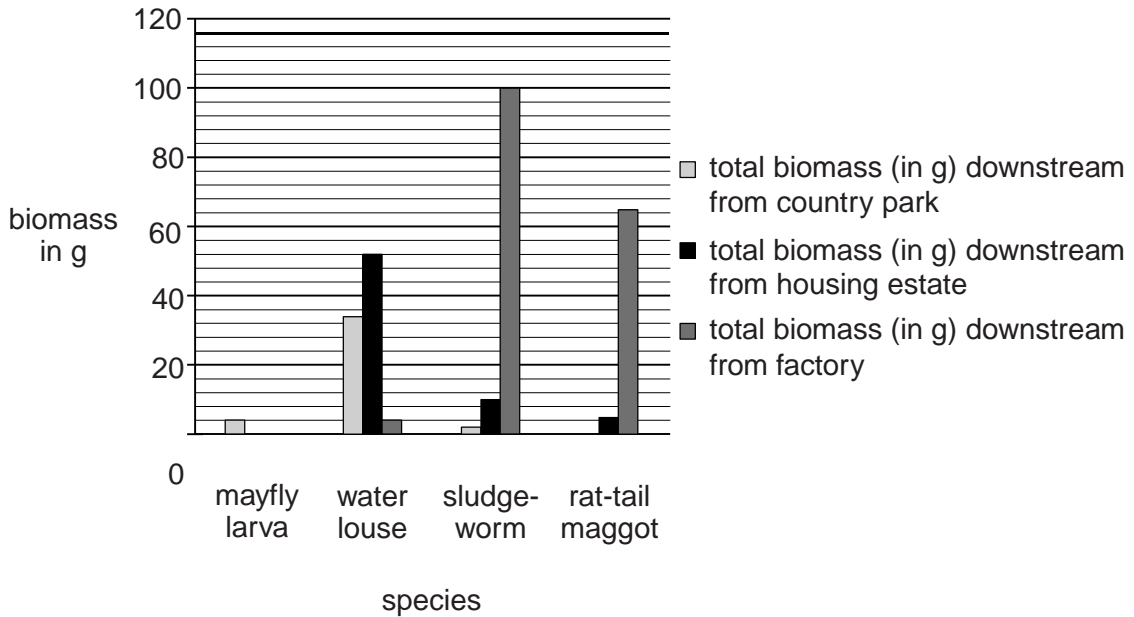

7 The picture shows a right whale.

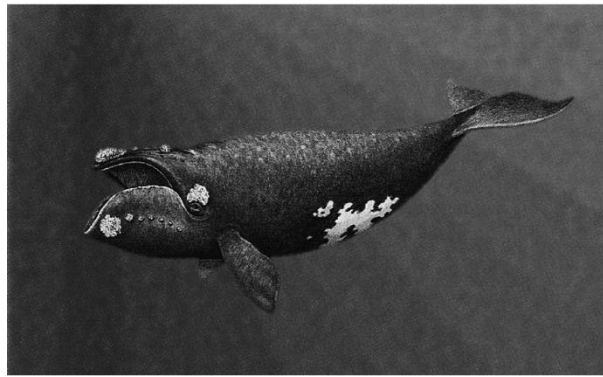

Biologists have measured the population of right whales in an area of the North Atlantic during five separate months.

They also measured the amount of food available in that area and the energy in that food.

Results were plotted on a graph.

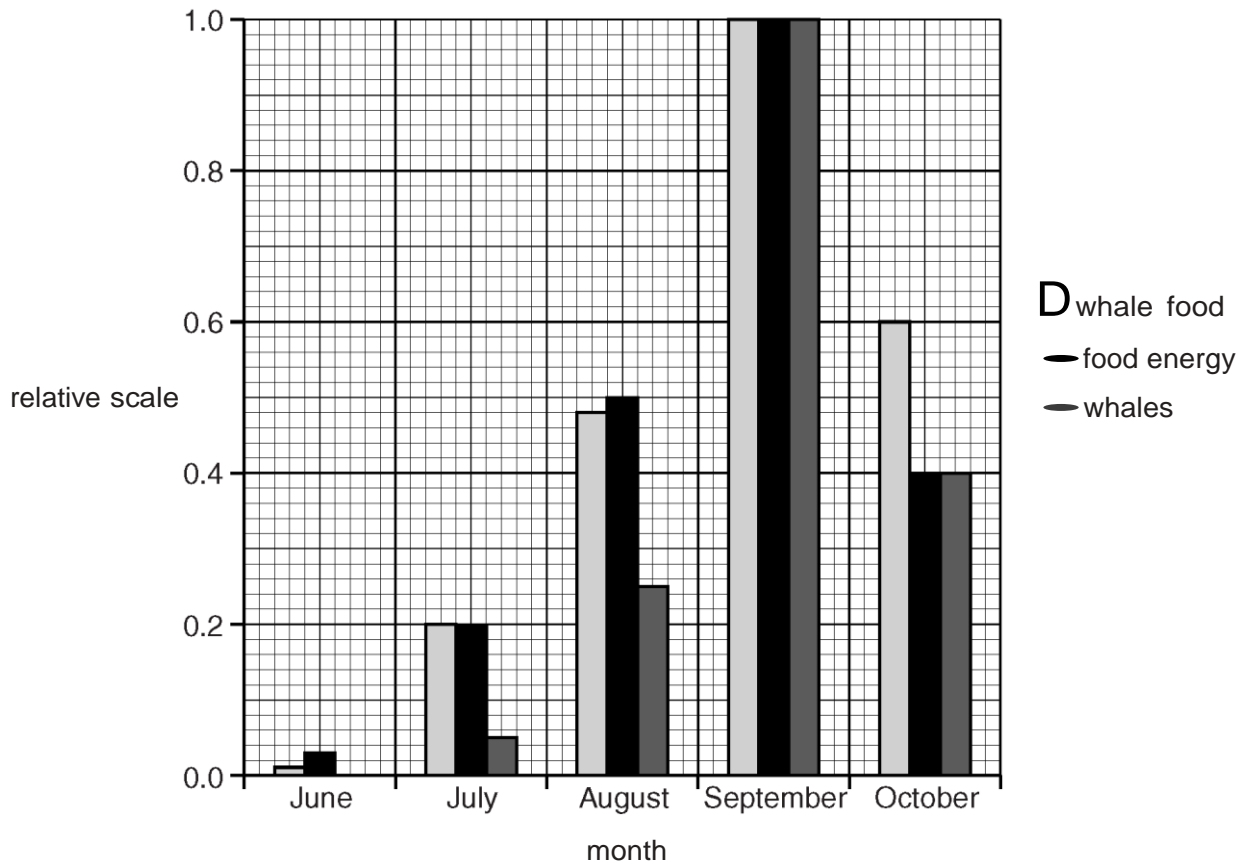

(a) (i) The ratio of whales to food energy in September and October is 1:1.
What is the ratio of whales to food energy in July?

hales: food energy ratio =¹

[2]

(ii) Right whales are critically endangered.

Biologists think their results show that whale food energy is linked to whale population size in a particular area.

They think it will allow them to predict where migrating whales can be found.

Use your answer from part (i) and information in the graph to evaluate their claims.

.....
.....
.....
.....
..... [3]

(b) Whales are thought to have evolved from animals similar to the hippopotamus by natural selection.

Put the following statements in the correct order, 1 to 4, to best explain the theory of evolution by natural selection.

The first one has been done for you. Write numbers 2 to 4 in the correct boxes.

<input type="checkbox"/>	competition for limited resources
<input type="checkbox"/>	inheritance of 'successful' adaptations
<input type="checkbox" value="1"/>	presence of natural variation
<input type="checkbox"/>	survival of the fittest

[2]

(c) The right whale is adapted to living in very cold environments.

What anatomical and behavioural adaptations does the right whale have to help it to survive in very cold environments?

.....
..... [2]

[Total: 9]

SECTION C – Module B3

8 Amy and Sarah are identical twins.

Their development began when an egg cell and sperm cell joined to form a zygote.

The zygote developed into an embryo made of many cells.

After about a week the embryo split into the two twin embryos.

The two embryos grew to become Amy and Sarah.

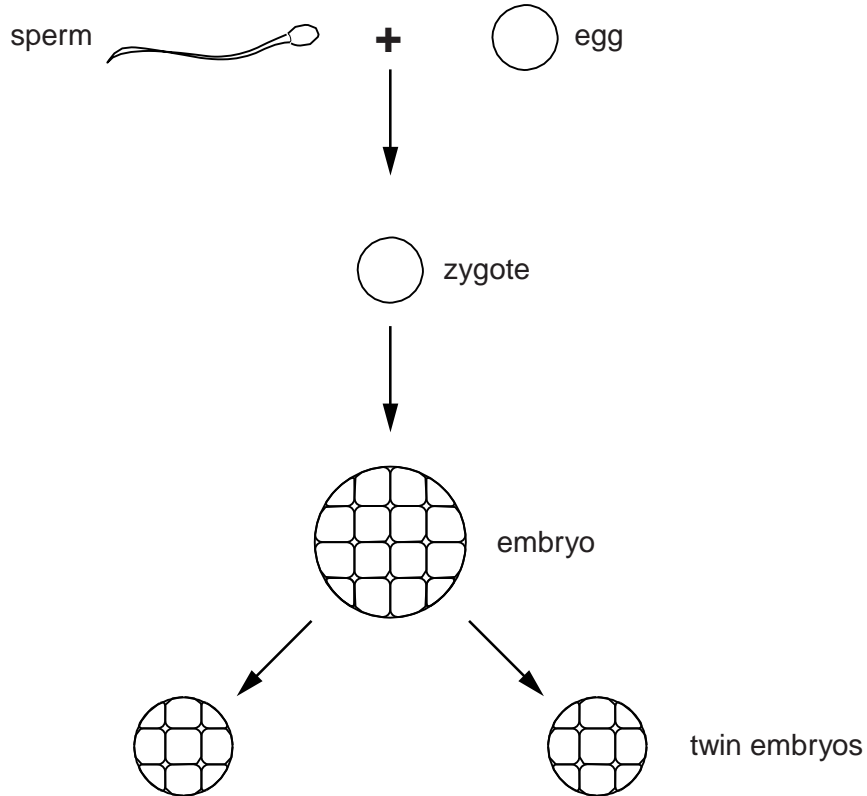

(a) Put **one** tick (✓) in **each** row of the table to show which cells are haploid and which are diploid.

	Haploid	Diploid
egg cell		
sperm cell		
zygote		
cells in embryo		
cells in twin embryos		

[2]

(b) What type of cell division happens to the zygote to form the embryo?

..... [1]

(c) As an embryo grows into a foetus (developing baby), one of the first organ systems that develops is the blood circulatory system.

(i) A human foetus has a double circulatory system.

Describe **one** advantage of a double circulatory system compared with a single circulatory system.

.....
..... [1]

(ii) The haemoglobin of a human foetus more readily combines with oxygen than the mother's haemoglobin combines with oxygen.

Suggest why this is important.

.....
.....
..... [2]

(iii) During growth, the foetus uses oxygen to produce ATP.

Why does the foetus need ATP?

..... [1]

[Total: 7]

Question 9 begins on page 18

- 9 The graphs, on this page and the next page, show height growth curves for girls and boys in the USA. The lines show percentiles.

For example, the top line shows the 95th percentile.

This means that 95% of girls or boys are at or below that height.

Girls, 2 to 20 years

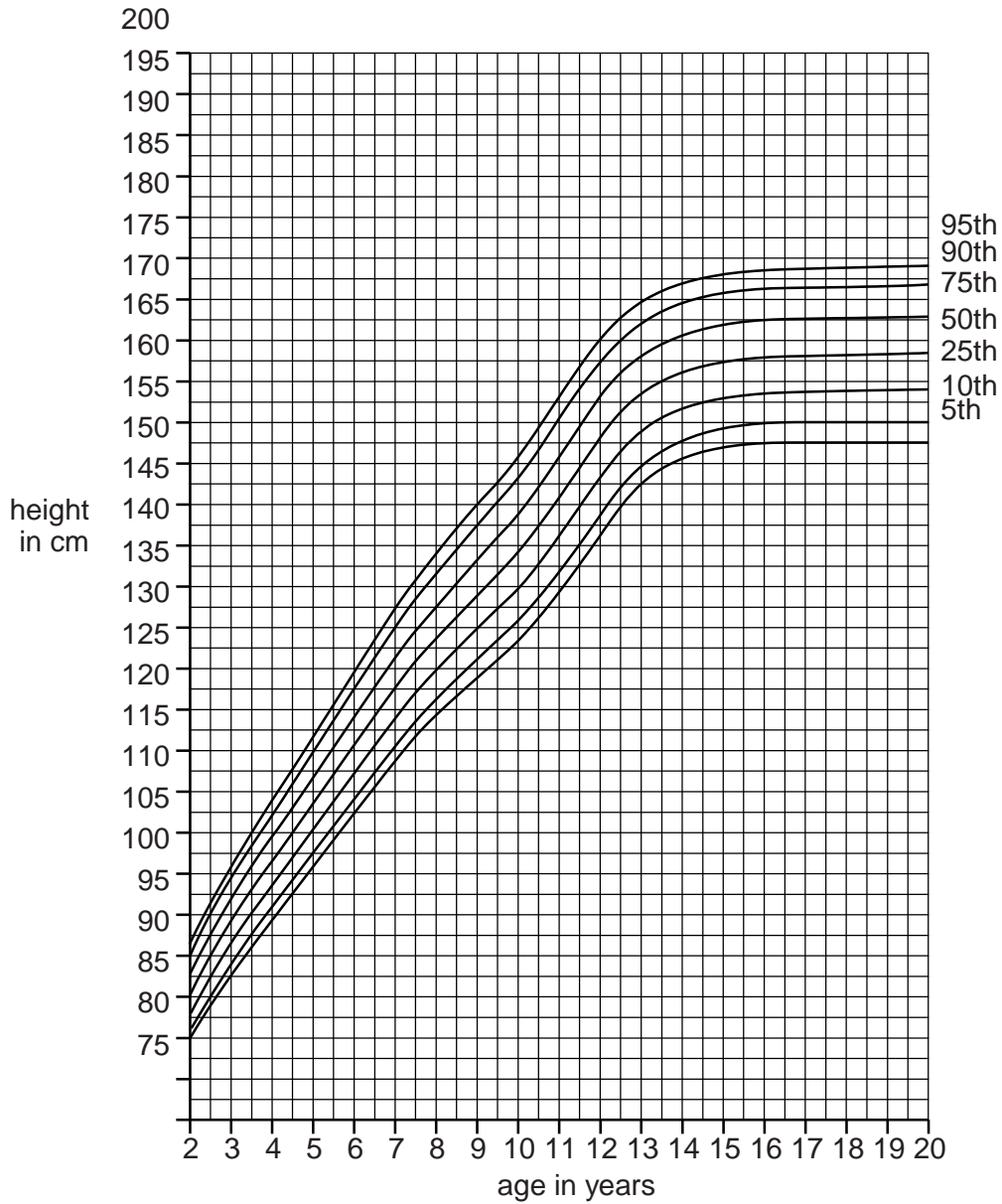

- (a) At what age is there most variation in the heights of girls?

Explain your answer.

.....

.....

.....

.....

[2]

Boys, 2 to 20 years

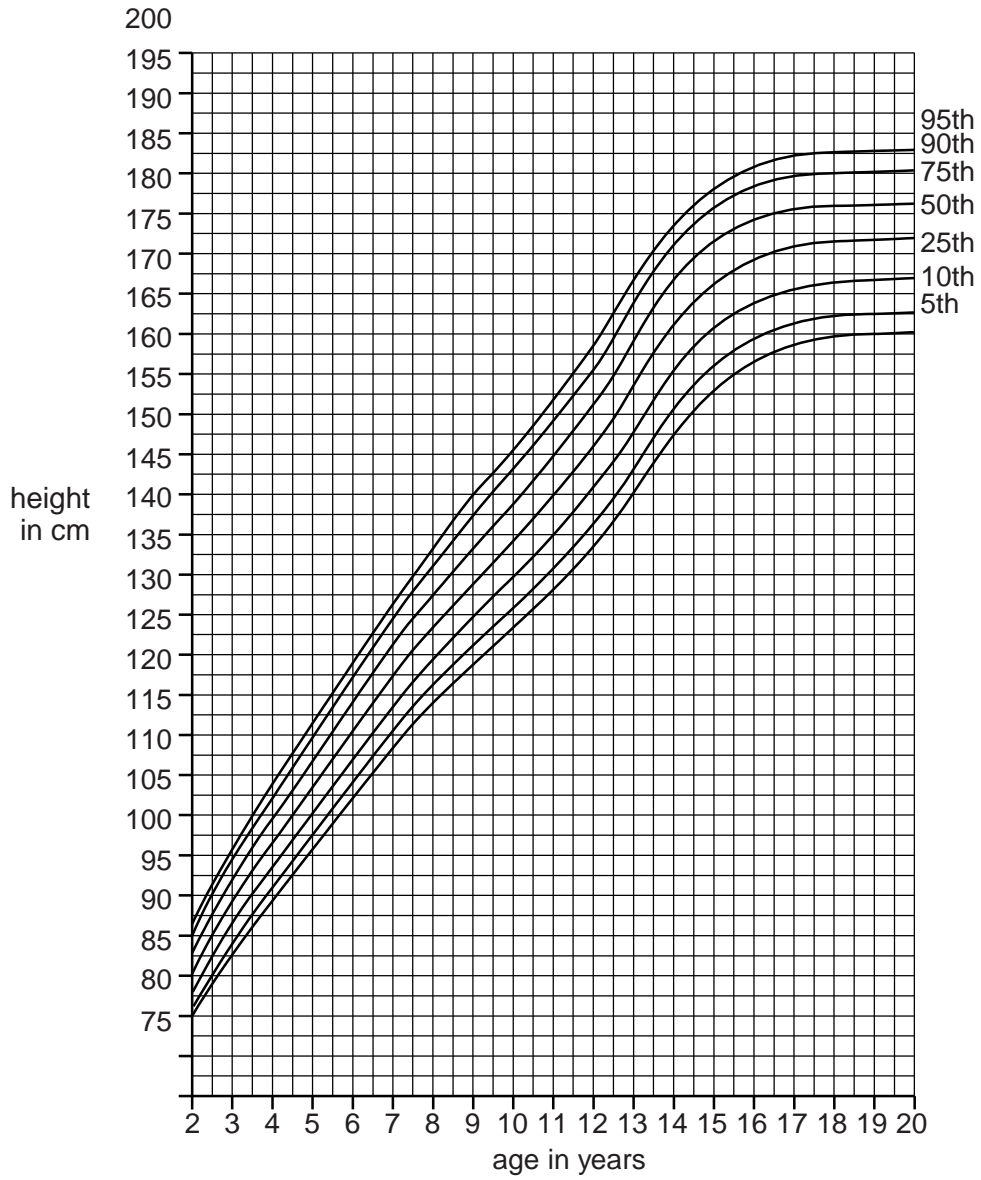

(b) Kash says that the graphs show that boys are taller than girls at age 20.

Discuss whether or not he is correct.

Use the graphs to help you answer.

.....

.....

.....

.....

[2]

(c) During growth, different types of protein are made and used.

(i) Write down **two** types of protein that do different jobs and describe the job of each protein during growth.

1

.....

.....

2

.....

.....

[4]

(ii) Proteins are coded for by DNA.

Describe how the DNA base sequence codes for a protein.

.....

..... [2]

[Total: 10]

10 Bulldogs have been produced by selective breeding to have a large head and a flat face.



(a) The large head means that many bulldogs have to be born by a Caesarean operation.

This means that the mother has to be cut open for the puppies to be born.

The bulldog's flat face often causes it to have breathing problems.

Some people think that the breeding of bulldogs should be banned for both health and genetic reasons.

Discuss the reasons for and against a ban on the selective breeding of bulldogs.

✍ *The quality of written communication will be assessed in your answer to this question.*

..... [6]

(b) If the selective breeding of bulldogs is **not** going to be banned, suggest how some of the health problems could be avoided in future generations.

.....

.....

.....

..... [2]

[Total: 8]

END OF QUESTION PAPER

BLANK PAGE

PLEASE DO NOT WRITE ON THIS PAGE

PLEASE DO NOT WRITE ON THIS PAGE



Copyright Information

OCR is committed to seeking permission to reproduce all third-party content that it uses in its assessment materials. OCR has attempted to identify and contact all copyright holders whose work is used in this paper. To avoid the issue of disclosure of answer-related information to candidates, all copyright acknowledgements are reproduced in the OCR Copyright Acknowledgements Booklet. This is produced for each series of examinations and is freely available to download from our public website (www.ocr.org.uk) after the live examination series.

If OCR has unwittingly failed to correctly acknowledge or clear any third-party content in this assessment material, OCR will be happy to correct its mistake at the earliest possible opportunity.

For queries or further information please contact the Copyright Team, First Floor, 9 Hills Road, Cambridge CB2 1GE.

OCR is part of the Cambridge Assessment Group; Cambridge Assessment is the brand name of University of Cambridge Local Examinations Syndicate (UCLES), which is itself a department of the University of Cambridge.